

Topic: Component Selection/Antenna Choice

Quarter 2 of the EEC 134 Senior Design can be quite a stressful ordeal due to the myriad of issues that can crop up at any given time. These issues can range from improperly made PCB to burnt out ICs to broken antennas and connectors. In order to reduce the amount of hair pulling and headaches, here is a general list of tips that our group found helpful in the completion of our design project.

1. When picking components for your design, learn how to properly understand the specifications of each component you are looking at. The mixer, VCO, attenuator, and splitter tend to be straight forward, but the RF amplifiers can cause a lot of issues. The issues mainly stem from the large number of characteristics an amplifier can have. For example, on the most basic level of characteristics we have frequency range of operation, voltage input, P1dB compression point, noise figure, and gain.

Figure 1. Digikey LNA specifications on a product listing

Manufacturer Part Number	Manufacturer	Description	Quantity Available	Unit Price USD	Minimum Quantity	Packaging	Series	Part Status	Frequency	P1dB	Gain	Noise Figure	RF Type	Voltage - Supply
MGA-634P8-TR1G	Broadcom Limited	IC LNA ULTRA LOW NOISE ACT BIAS	14,048 - Immediate	5.51000	1	Cut Tape (CT) Alternate Packaging	-	Active	1.5GHz ~ 2.3GHz	21dBm	17.4dB	0.44dB	CDMA, GSM	5V

These points alone are already a lot to keep track of, but beyond this we also have device schematic layout and frequency to gain performance graphs to be aware of. If you find a device that has great characteristics you need to make sure that it performs just as well under the circumstances you intend on using it for. On top of this, you do not want to buy components with overly complicated specs or a million different surface mount passives. This can cause a headache later when filing orders for components and organizing/soldering your PCBs.

Figure 2. Schematic for LNA at 1.9 GHz

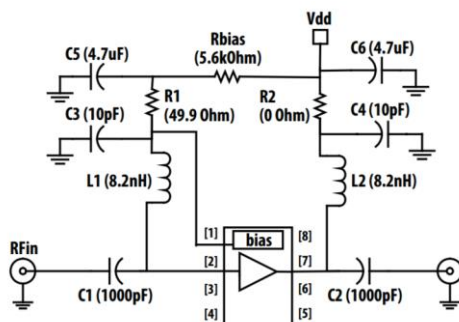
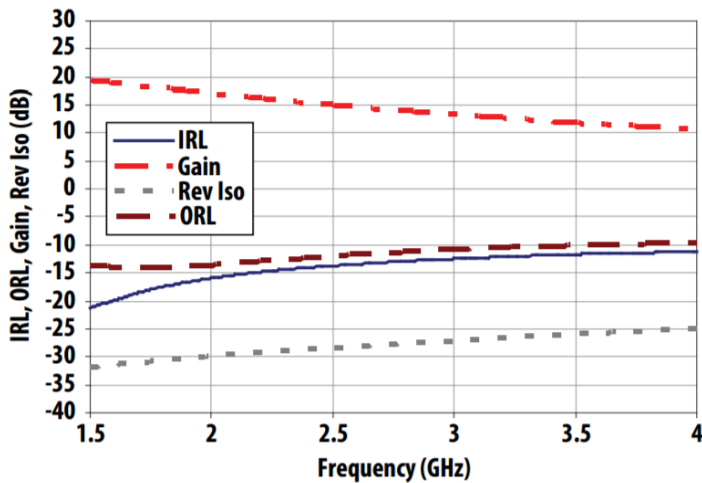

Figure 3. Gain performance depending on frequency



Note: Notice how the gain rapidly diminishes with respect to frequency. If we wanted to operate at a range of 2.3-2.5 GHz, we would observe a 5-6 dB gain drop.

2. In this section, I am going to discuss antenna choice for the final design of the project. Before going any further, as a disclaimer, I am not well versed with how antennas work or how to design them. However, my group and I have experimented around with purchased antennas and the can antennas that we built quarter 1. We have tried many configurations and results gave us many useful insights on what allows for best performance.

Firstly, do not underestimate the can antennas. If designed correctly, they work astonishingly well for what they are and we were able to get excellent results using just those. If you are running short on time, I would recommend that you stick with them.

Secondly, experimentation is key. For our second antenna alternative, we used a set of 2.4 GHz Yagi Antennas purchased from Kent Electronics on Ebay for 5 dollars each. They had relatively high directivity and were well suited for our purposes. Upon receiving them, we assembled and tested them as a pair and compared the results to the can antenna results. To our surprise, the little makeshift cans actually annihilated the performance of the Yagi antennas. After trying the two Yagi antennas together, we decided to try the Yagi on the transmitter and one of the cans on the receiver. This configuration was the best one yet. We significantly increased the effective range and visibility of objects at distances.

Thirdly, do not hesitate to try antenna arrangements that you are uncertain of. It is better to test a configuration and confirm that it is inferior than to have missed out on the potential best configuration. For example, after seeing great results with the Yagi antenna as the transmitter and the can antenna as the receiver, I was certain that it was the best configuration. Therefore, I resisted the idea of swapping their positions. After some

convincing from my design partners, I relented to spending the hour testing this different configuration. Much to my surprise, this setup turned out to be the best out of all of them.

In summation, antenna choice should not be a teams primary concern. The goal of the project is to construct a working a radar and the cans will work fine for that purpose. However, that does not mean that the topic should be ignored by any of the teams. Acquiring suitable antennas and doing some experiments, given that your system works, provides an easy way to see a significant improvement in system performance.



Figure 4. Final Antenna configuration

For those who are interested in what configuration worked best for us, we experienced the most success using the “cyclops” setup. We used a commercially available antenna to either transmit or receive, but never for both. **The reasoning behind doing so is the fact that using both the Yagi antennas at the same time greatly increased cross talk.** We had to significantly decrease the gain of the Baseband amplifier in order to not destroy the sound card in the computer. After running some tests, we found that the system suffered from a lot of noise and our range was halved. It should be noted that the cans do not seem to have this problem and work fine when paired together.